



SB.10 HEAVY DUTY BOLLARD

INFORMATION AND INSTALLTION RECOMMENDATIONS

Our SB.10 is available in various diameters and the option to bolt down or concrete in to suit your site requirements.

Perfect for restricting access or creating demarcation in areas such as car parks, retail parks or anywhere similar.

These are also a great solution for protecting shutter doors, openings or areas requiring heavy duty protection.

Galvanised as standard. Powder coated finish is available as at extra cost. Hi visibility banding also available on request as an extra cost

All bolt down options are supplied 900mm high (Other heights are available upon request)

All concrete in options are supplied with an overall length of 1200mm (Other lengths are available on request)

Diameters available (others are available on request)

- 76mm
- 90mm
- 114mm
- 139.7mm

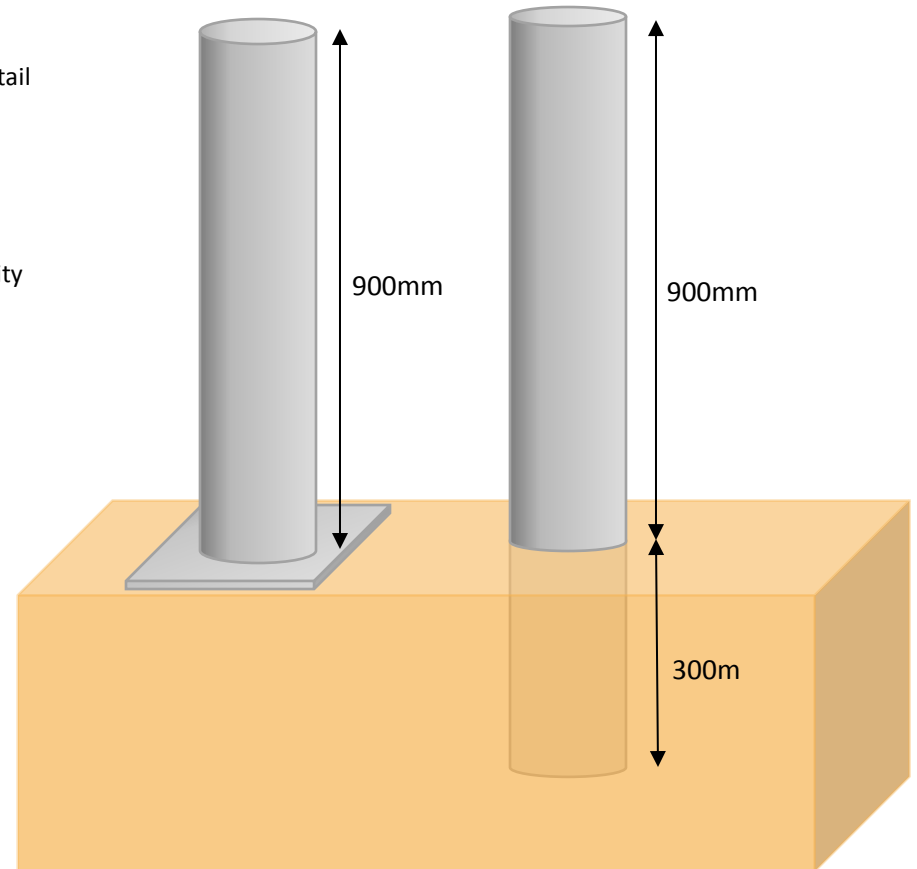



(Read in full before starting)

SAFETY

- We recommend the following minimum precautions are taken:
- Wear appropriate safety clothing.
- Eye protection and hand protection should be worn when mixing concrete.
- Wear strong protective gloves.
- Secure site from pedestrians and vehicles, where applicable, by the use of high visibility tape, barriers, cones, safety lamps etc.
- If you use a power supply ensure that it is secure and in a safe and dry location.
- Ensure there are no underground services that may be affected.

INSTALLATION INSTRUCTIONS

Ragged/Cast in versions

- Determine the position of the installation. Break the surface and make a hole approx. 300mm square x 400mm deep depending on size of bollard and site conditions.
- Place the bollard in the Centre of the hole and ensure it is vertical with a spirit level and fill the rest of the hole with concrete, allow to fully dry.

Flanged/Bolt down versions

- Determine the position of the installation and ensure the surface is suitable – preferably concrete at least 400mm x 400mm cube. Use the bolt holes in the flange plate for a template and drill holes for the bolts. Bolt the bollard into position under the surface of the flange resting flat on the ground, making sure the bolts are securely tightened. The drilling hole depth and diameter will depend in the type of bolt being used. Fixing down bolts are available extra.

MAINTENANCE

- Clear out all debris and leaves from the base.
- Occasionally clean all surfaces with soap and water.
- For flanged versions, check the bolts remain securely tightened.

Base plate for diameters up to 114mm

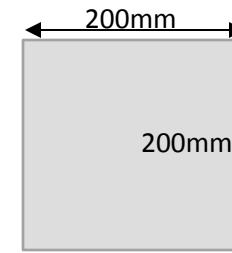

Base plate for diameter 139mm only

